

# Technical data OPL 10 (2.1)

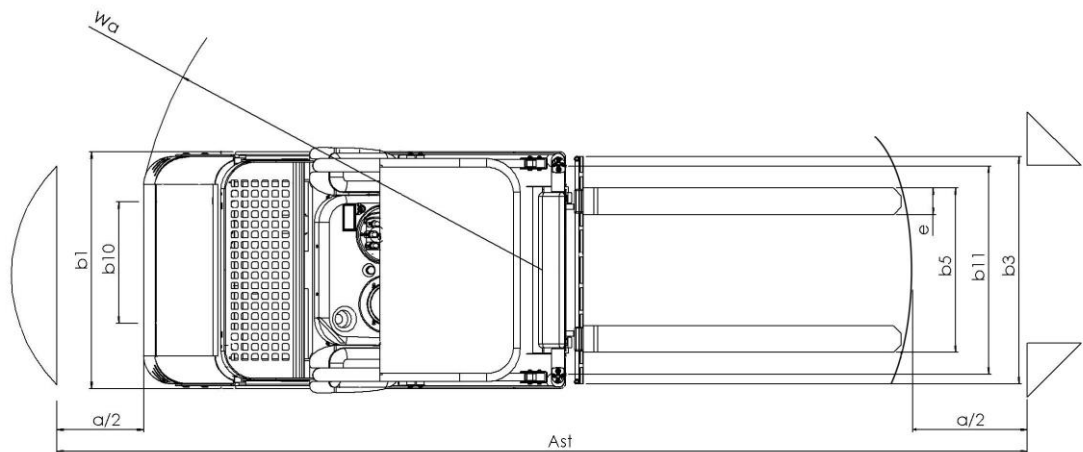
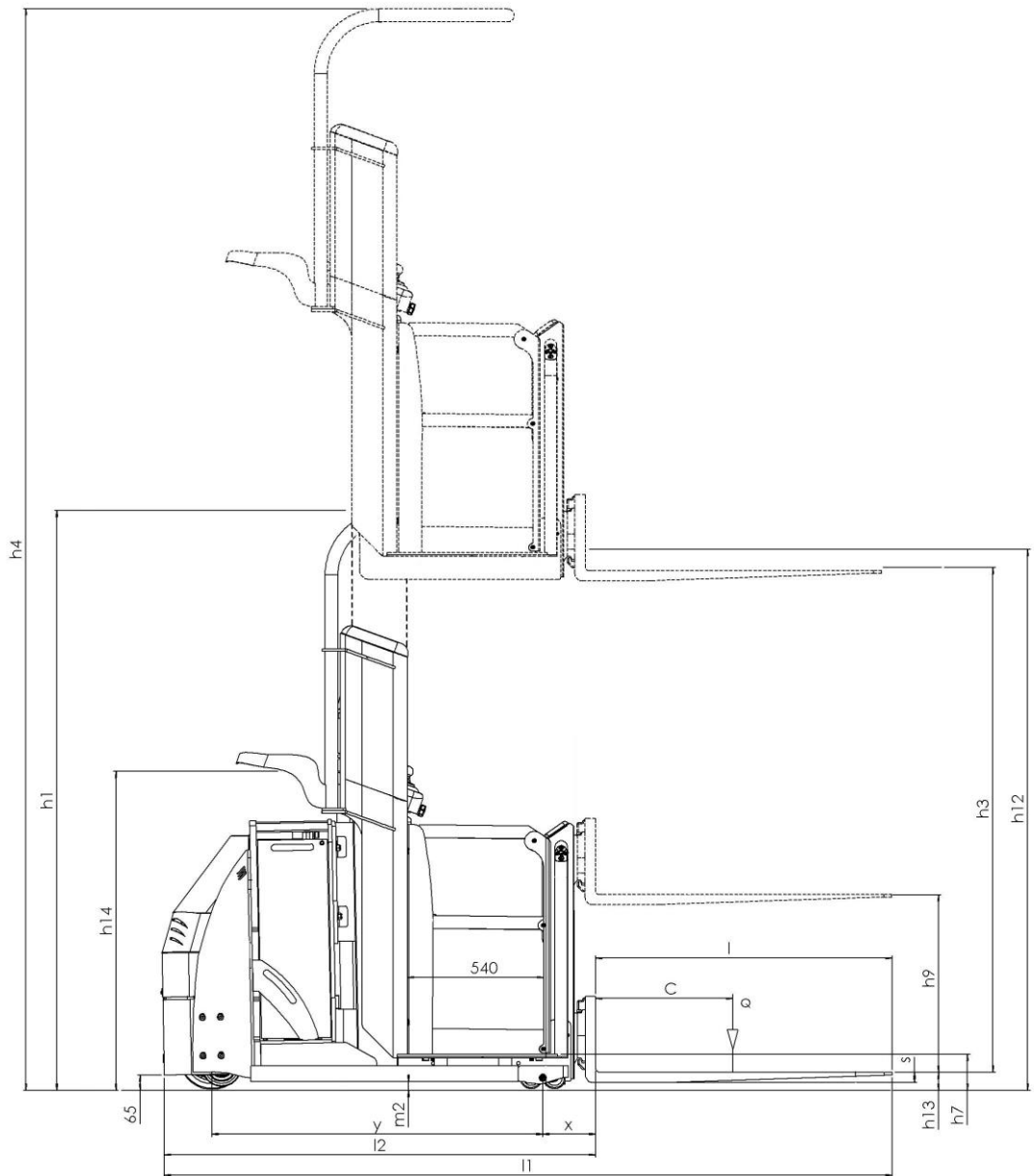

Characteristics	1.1	Manufacturer		Actil
	1.2	Model designation		OPL 10
	1.3	Power unit		Battery
	1.4	Operation		Order picker
	1.5	Load capacity	Q (t)	1,0
	1.6	Load center	c (mm)	500
	1.8	Axle centre to fork face	x (mm)	131
	1.9	Wheelbase	y (mm)	1305
	Weights	2.1	Service weight	(kg)
2.2		Axle load with load, drive side/load side	(kg)	702/2480
2.3		Axle load without load, drive side/load side	(kg)	1146/900
Wheels/tyres	3.1	Tyres		Polyurethane
	3.2	Tyre size, drive side		Ø255x125
	3.3	Tyre size, load side		4xØ85x60
	3.5	Wheels, number drive side/load side (x=driven wheels)		1x+2/4
	3.6	Track width, drive side	b10 (mm)	532
	3.7	Track width, load side	b11 (mm)	765
Dimensions	4.2	Height of mast, lowered	h1 (mm)	2250
	4.4	Lift	h3 (mm)	1970
	4.5	Height of mast, extended	h4 (mm)	4 220
	4.8	Stand height	h7 (mm)	130
	4.9	Height of steering wheel in operating position, min/max	h14 (mm)	1180/1230
	4.11	Additional lift	h9 (mm)	700
	4.12	Platform height, raised	h12 (mm)	2100
	4.15	Fork height, lowered	h13 (mm)	70
	4.19	Overall length	l1 (mm)	2816
	4.20	Length to fork face	l2 (mm)	1616
	4.21	Overall width	b1 (mm)	885
	4.22	Fork dimensions	s/e/l (mm)	40/100/1200
	4.25	Width across forks	b5 (mm)	545
	4.32	Ground clearance, centre of wheelbase min/max	m2 (mm)	27/27
	4.34	Aisle width with pallet 800x1200 crossways/lengthways	Ast (mm)	3132/3170
	4.35	Turning radius	Wa (mm)	1505
4.39	Aisle width without pallet	Ast (mm)	3132	
Performance	5.1	Travel speed, with/without load	(km/h)	12/12
	5.2	Lifting speed, with/without load	(m/s)	0,18/0,24
	5.3	Lowering speed, with/without load	(m/s)	0,36/0,29
	5.7	Gradeability, laden/unladen	(%)	3,7/4
	5.10	Service brake		Electric
Drive	6.1	Drive motor S2 60 minute rating	(kW)	3,0
	6.2	Lift motor rating at S3 15%	(kW)	1.2+1.2
	6.4	Battery voltage/rated capacity (5h)	(V/Ah)	24/620
	6.5	Battery weight (±5%)	(kg)	480
Others	8.1	Type of drive control		Electronic
	8.4	Noise level at operator's ear	(dB(A))	<70

Alternative mast types, tyres, equipment, etc. could result in different values. See mast and equipment list.

All technical data according to VDI. 2198.

Performance and dimensions are displayed with reservation for tolerance.