

# Technical data N10S/N15S

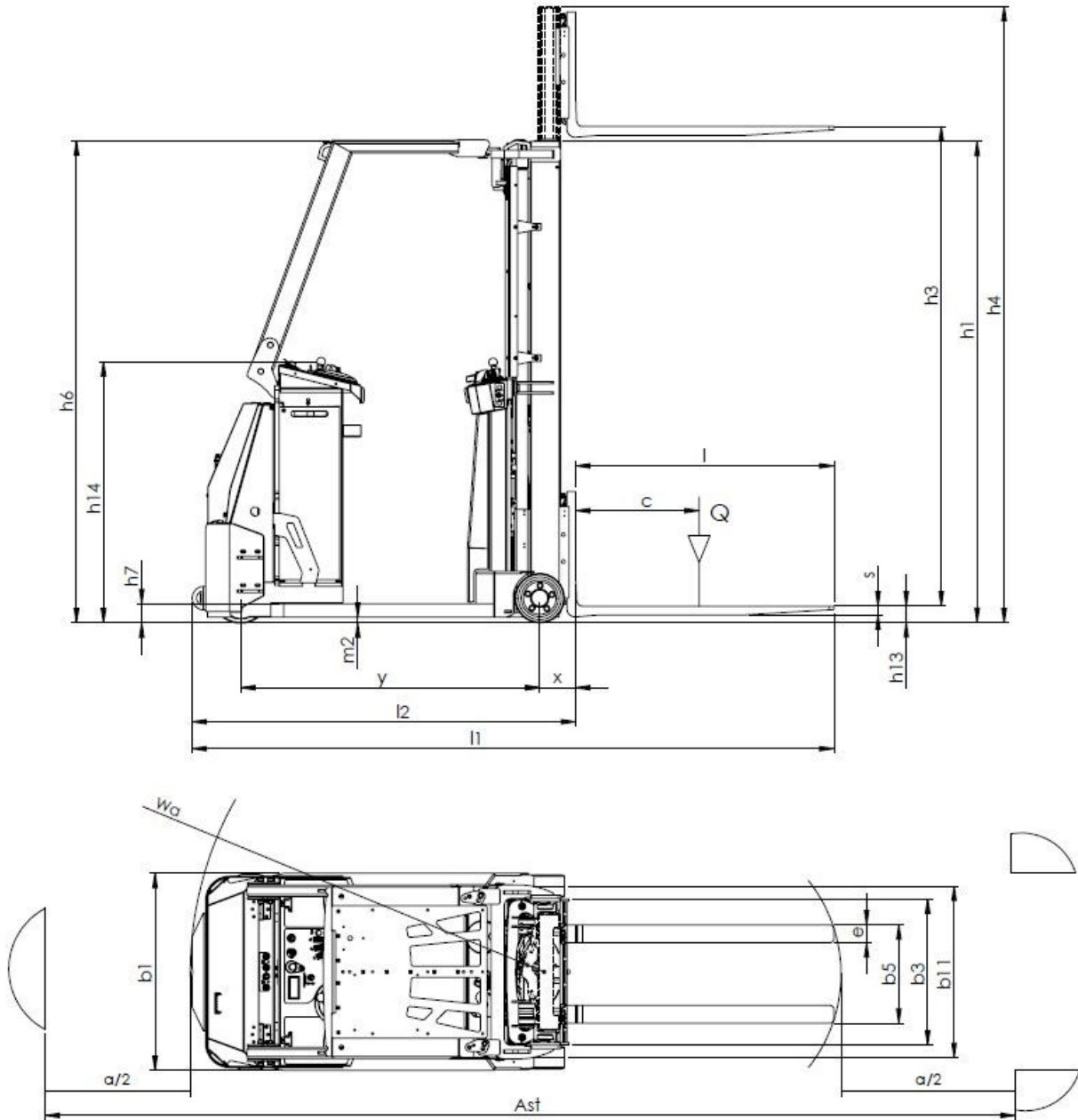

Characteristics	1.1	Manufacturer		Actil	Actil
	1.2	Model designation		N10	N15
	1.3	Power unit		Battery	Battery
	1.4	Operation		Order picker	Order picker
	1.5	Load capacity	Q (t)	1,0	1,5
	1.6	Load center	c (mm)	600	600
	1.8	Axle centre to fork face	x (mm)	210	220
Weights	1.9	Wheelbase	y (mm)	1317	1460
	2.1	Service weight	(kg)	2128	2432
	2.2	Axle load with load, drive side/load side	(kg)	528/2600	532/3400
Wheels/tyres	2.3	Axle load without load, drive side/load side	(kg)	1068/1060	1372/1060
	3.1	Tyres		Tractothan	Tractothan
	3.2	Tyre size, drive side		Ø254x115	Ø254x115
	3.3	Tyre size, load side		2xØ220x100	2xØ220x100
	3.5	Wheels, number drive side/load side (x=driven wheels)		1x/2	1x/2
Dimensions	3.7	Track width, load side	b11 (mm)	830	830
	4.1	Fork carriage tilt, up / down	a / b (°)	4/2	4/2
	4.2	Height of mast, lowered	h1 (mm)	2190	2190
	4.3	Free lift	h2 (mm)	1630	1630
	4.4	Lift	h3 (mm)	4826	4826
	4.5	Height of mast, extended	h4 (mm)	5377	5377
	4.7	Height of overhead guard	h6 (mm)	2290	2290
	4.8	Stand height	h7 (mm)	90	90
	4.9	Height of steering wheel in operating position, min/max	h14 (mm)	1150/1150	1150/1150
	4.15	Fork height, lowered	h13 (mm)	50	50
	4.19	Overall length	l1 (mm)	2918	3063
	4.20	Length to fork face	l2 (mm)	1718	1863
	4.21	Overall width	b1 (mm)	900	900
	4.22	Fork dimensions	s/e/l (mm)	40/100/1200	40/100/1200
	4.23	Fork carriage to ISO 2328, class/type A, B		2A	2A
	4.24	Fork-carriage width	b3 (mm)	870	870
	4.25	Width across forks	b5 (mm)	315/515/770	315/515/770
	4.32	Ground clearance, centre of wheelbase min/max	m2 (mm)	20/20	20/20
	4.34	Aisle width with pallet 800x1200 crossways/lengthways	Ast (mm)	3175/3213	3317/3355
4.35	Turning radius	Wa (mm)	1548	1679,86577	
Performance	4.39	Aisle width without pallet	Ast (mm)	3175	3317
	5.1	Travel speed, with/without load	(km/h)	8/12	8/12
	5.2	Lifting speed, with/without load	(m/s)	0.21/0.43	0.21/0.43
	5.3	Lowering speed, with/without load	(m/s)	0.44/0.32	0.44/0.32
	5.8	Maximum climbing ability, with /without load	(%)	7/7	7/7
Drive	5.10	Service brake		Electric	Electric
	6.1	Drive motor S2 60 minute rating	(kW)	3,0	3
	6.2	Lift motor rating at S3 15%	(kW)	5.7	5.7
	6.4	Battery voltage/rated capacity (5h)	(V/Ah)	24/620	24/775
	6.5	Battery weight (±5%)	(kg)	500	610
Others	8.1	Type of drive control		Electronic	Electronic
	8.4	Noise level at operator's ear	(dB(A))	<70	<70

Alternative mast types, tyres, equipment, etc. could result in different values. See mast and equipment list. All technical data according to VDI. 2198.

Performance and dimensions are displayed with reservation for tolerance.