

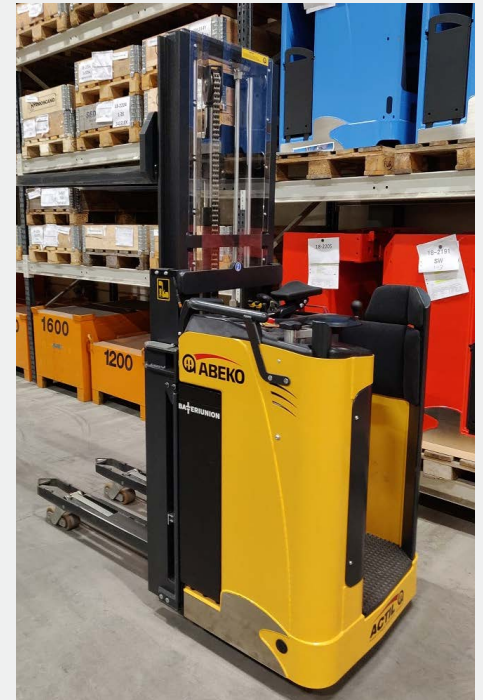

SA-N 16 - an investment that pays off

The SA-N 16 is a small, narrow and compact truck. It is even slimmer than the EUR pallet. Unlike conventional pedestrian stacker with a flip-down platform the driver stands protected inside the truck. Due to this the SA-N 16 also becomes significantly shorter. The truck can be equipped with hydraulic shock absorber and spring loaded castor wheels which provides incredible comfort and saves wear and tear when driving over joints.



A workplace for healthier drivers
Ergonomics and operator safety with top-class driver protection and a work environment that is built on the basis of the driver's safety and comfort.

Innovation that pays off
The key to the best overall economy is high quality, reliability and long life. In these areas, ABEKO is at the absolute forefront.

Big possibilities in a compact unit
The SAN DS comes as standard with initial lift for double stacking. Higher lift heights can also be offered.

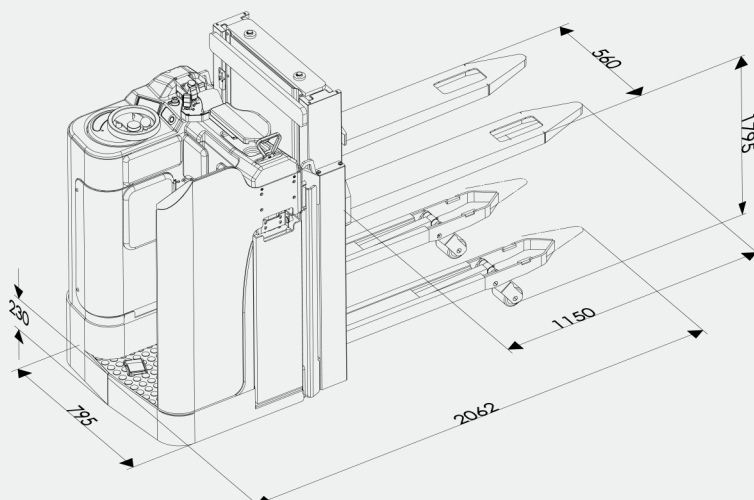

Safety

Speed reduce The driving speed drops continuously in turns

Pulsing brake Minimise the risk for the drive wheel locking or separating from the surface when braking

Lowering speed compensation Lowering Speed Compensation The truck's lowering speed is set automatically depending on the tonnage on the forks